

DATA SHEET

FDT Solarfix universal



Description

The universally applicable solar support was specifically developed for the mechanical fastening of common PV systems. However, it can also be used to secure railings, structures, and technical equipment.

The FDT Solarfix universal enables an easy separation of trades between roofers and solar installers. The PV system manufacturer typically calculates the required array rows and support spacing.

The systems are optimally protected against movement and uplift. Ballasting to keep PV panels in place can be completely eliminated, which permits the installation of PV systems even on roofs with limited structural load capacity. The connection thread allows for a system-specific connection of common PV systems.

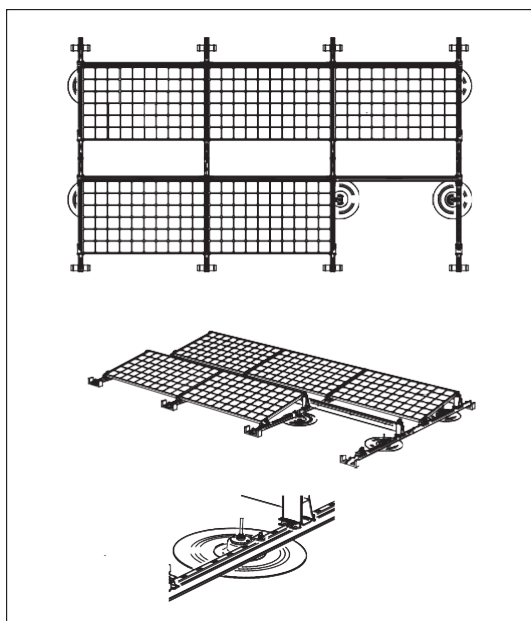

Scope

The FDT Solarfix universal can be used on uninsulated and insulated flat roofs or pitched roofs (up to 20° roof pitch). The necessary fasteners to fix the solarfix on wooden and metal substrates can be supplied in required lengths up to 300 mm and are offered separately.

For insulated constructions, thermal insulation with the following minimum specifications can be used:

1. EPS thermal insulation according to EN 13163, Compressive strength at least 150 kpa
2. Mineral wool according to EN 13162,
3. Compressive strength at least 70 kpa
4. PUR thermal insulation according to EN 13165, Compressive strength at least 100 kpa

The permissible vertical and horizontal forces in combination with the fastening elements were tested and determined by DEKRA Testing and Certification GmbH.

Product advantages

- Compatible with all common PV constructions
- Suitable for flat and low sloped roof
- Compatible with Rhenofol PVC, Rhepanol PIB, UltraPly TPO, RubberGard EPDM and RubberCover EPDM roofing membranes
- Low installation height
- Low weight
- The risk from point loads is minimized

Packaging

The FDT Solarfix universal consists of 12 components:

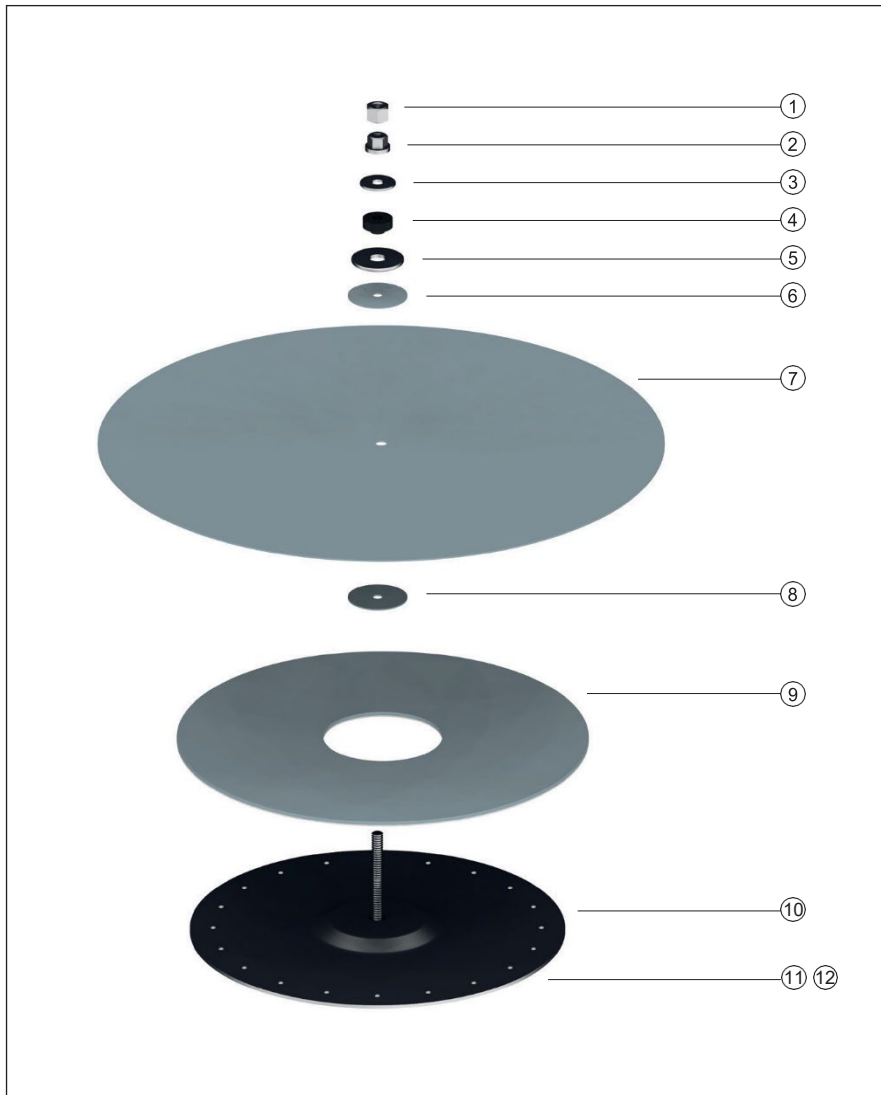

- | | |
|--|--|
| ① Lock nut M10 | ⑧ Sealing disc 1 made of Rhepanol h/ Rhenofol C/ UltraPly TPO/ EPDM, A-Ø = 50 mm and I-Ø = 8 mm |
| ② Flange nuts M10 | ⑨ Protective bearing ring made of Rhepanol hfk/ Rhenofol CGv, A-Ø = 345 mm and I-Ø = 100 mm, thickness 2.5 mm
Protective bearing ring made of Rhepanol hfk for EPDM A-Ø = 315 mm and I-Ø = 100 mm, thickness 2.5 mm |
| ③ Washer, A-Ø = 30 mm and I-Ø = 10 mm, Thickness 2 mm | ⑩ Base plate, A-Ø = 315 mm, height 12 mm, with holes for mechanical fastening |
| ④ Rubber washer, Thickness 8 mm, A-Ø = 25 mm | ⑪ Washer, A-Ø = 30 mm and I-Ø = 10 mm, Thickness 2 mm |
| ⑤ Washer, A-Ø = 44 mm und I-Ø = 14 mm, Thickness 3 mm | ⑫ Threaded bolt, bolt M10, length 107 mm |
| ⑥ Sealing disc 2 made of Rhepanol h/ Rhenofol C/ UltraPly TPO/ EPDM, A-Ø = 50 mm and I-Ø = 8 mm | |
| ⑦ Rhepanol hg/ Rhenofol CG/ UltraPly TPO/ sealing sleeve, A-Ø = 475 mm and I-Ø = 10 mm, Thickness 1.5 mm
QuickSeam SA Flashing sealing sleeve, A-Ø = 450 mm and I-Ø = 10 mm, Thickness 1.5 mm | |

Installation instructions

The roofer installs the supports at the calculated distances and connects the supports via appropriate sleeve with the surface seal. The thread allows the PV systems to be connected in a system-specific manner.

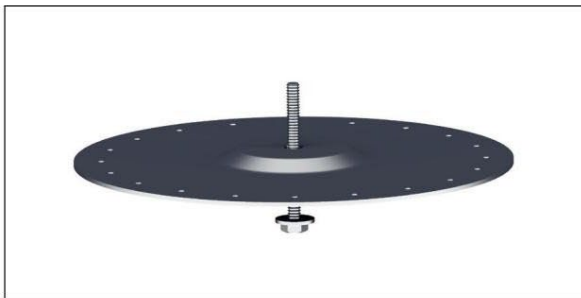

Step 1

Assembling the FDT Solarfix universal. To begin with, the threaded bolt with the washer is inserted through the base plate from below.

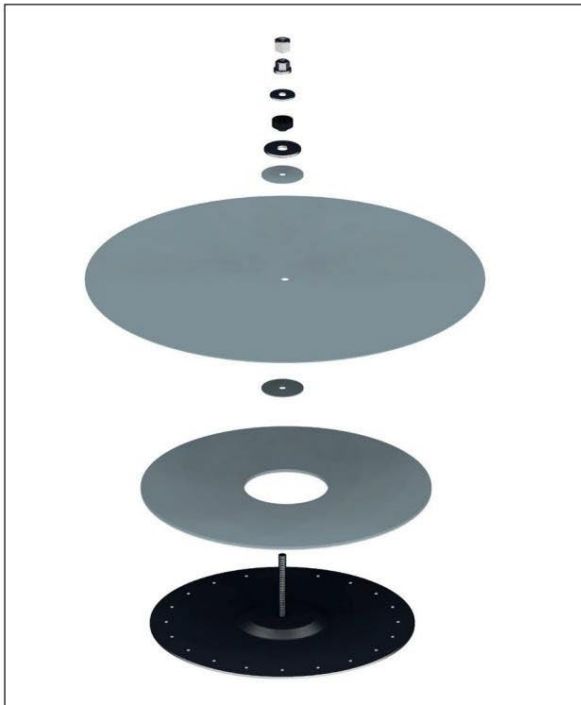

Step 2

All other components must be assembled in the order shown below:

1. Protective bearing ring
2. Sealing disc 1
3. Sealing sleeve
4. Sealing disc 2
5. Washer (large)
6. Rubber washer
7. Washer (small)
8. Flange nut M10
9. Lock nut M10



Step 3

Check that all parts have been installed in the correct order. The screw connection is tightened with a torque wrench (17 mm socket) and an open-end wrench (size 15) secured with **5 Nm** to ensure the tightness of the system.

Finally, the counter nut is fitted to prevent the system from untwisting (e.g. due to vibrations).

Mounting on metal deck

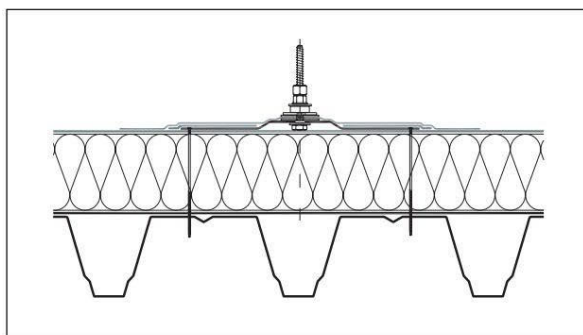
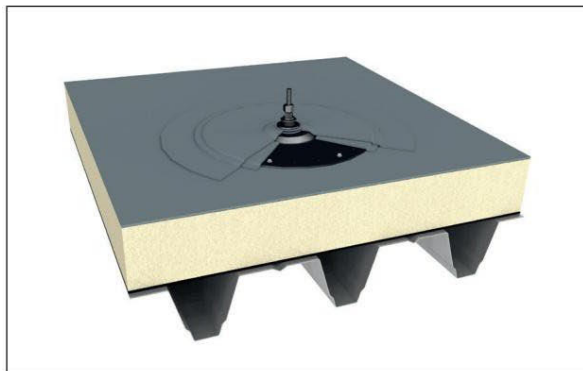
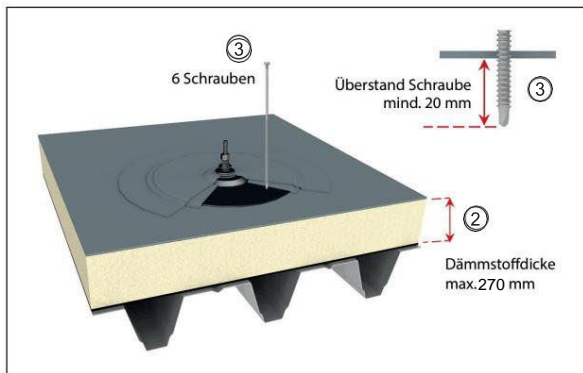

① Metal deck

For substrates made of trapezoidal metal deck, sheet thicknesses of 0.75 mm to 2.5 mm are possible for the mechanical fastening of the FDT Solarfix universal, with a maximum of 2.5 mm for double layers of sheet metal. The FDT Solarfix universal must be positioned so that it can be fastened to two flutes on metal deck.

Trapezoidal metal sheets must be dimensioned according to the static requirements.

② Insulation material

Insulation thickness max. 270 mm (Requirements for the insulation material see page 1).

③ Fasteners

Each solar bracket must be secured to the flute of the metal deck with at least six fasteners. Distribute the fasteners as evenly as possible across both top flutes use 4.8 mm thick fasteners for an insulation thickness up to 270 mm.

Attention

The fasteners are not included in the scope of delivery and must be ordered in the appropriate length.

The fastener must protrude at least 20 mm above the trapezoidal sheet on the underside.

Notice

Only the fasteners tested in the system must be used. We cannot accept responsibility for the use of other fasteners.

Mounting on wooden substrate

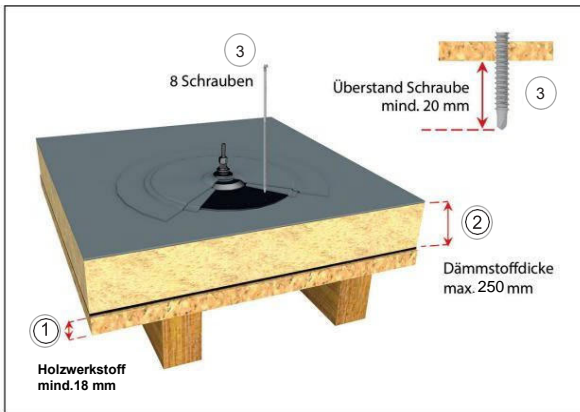

1 Wooden substrate

For substrates made of wooden substrate (eg. OSB), a minimum thickness of 18 mm is required for mechanical fastening of the FDT Solarfix universal. The wooden substructure must be dimensioned according to the structural requirements.

2 Insulation material

Insulation thickness max. 250 mm (Requirements for the insulation material see page 1).

3 Fasteners

Each solar holder must be secured to the wood material with at least 8 fasteners use 4.8 mm thick fasteners for an insulation thickness up to 250 mm.

Attention

The fasteners are not included in the scope of delivery and must be ordered in the appropriate length.

The fastener must protrude at least 20 mm through the wooden substrate.

Notice

Only the fasteners tested in the system must be used. We cannot accept responsibility for the use of other fasteners.

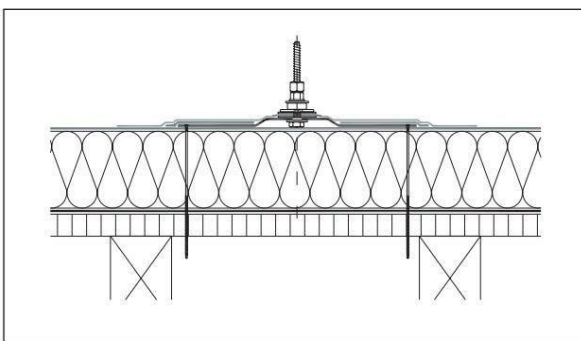
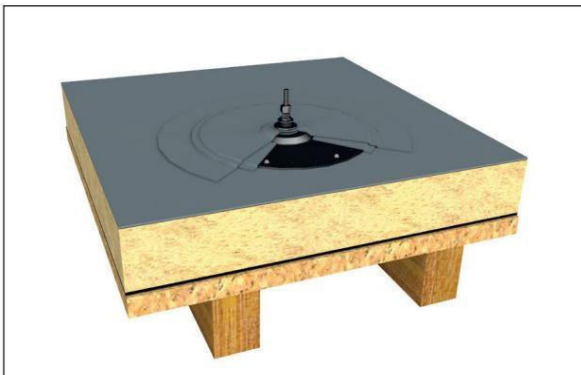

System matrix FDT Solarfix universal

Roof pitch	Substructure	Thermal insulation	fasteners	forces	Remarks
0 – 5°	Metal deck min. 0.75 mm	EPS according to EN 13163 min. 150 kpa, thickness max. 270 mm	Min. 6 fasteners	Fv = 6.0 KN Fh = 3.62 KN	The fastening of the PV system to the thread is only up to a maximum height of 75 mm permissible.
0 – 5°	Metal deck min. 0.75 mm	MW according to EN 13162 min. 70 kpa, thickness max. 270 mm	Min. 6 fasteners	Fv = 6.0 KN Fh = 3.62 KN	
0 – 5°	Metal deck min. 0.75 mm	PIR according to EN 13165 min. 100 kpa, thickness max. 270 mm	Min. 6 fasteners	Fv = 6.0 KN Fh = 3.62 KN	
0 – 5°	Wooden substrate OSB min. 18 mm	EPS according to EN 13163 min. 150 kpa, thickness max. 250 mm	Min. 8 fasteners	Fv = 7.0 KN Fh = 6.21 KN	
0 – 5°	Wooden substrate OSB min. 18 mm	MW according to EN 13162 min. 70 kpa, thickness max. 250 mm	Min. 8 fasteners	Fv = 7.0 KN Fh = 6.21 KN	
0 – 5°	Wooden substrate OSB min. 18 mm	PIR according to EN 13165 min. 100 kpa, thickness max. 250 mm	Min. 8 fasteners	Fv = 7.0 KN Fh = 6.21 KN	
>5° – 20°	Metal deck min. 0.75 mm	EPS min. 150 kpa, thickness max. 270 mm MW min. 70 kpa, thickness max. 270 mm PIR min. 100 kpa, thickness max. 270 mm	Min. 6 fasteners	Fv = 6.0 KN Fh = 3.62 KN	The fastening of the PV system to the thread is only up to a maximum height of 50 mm permissible.
>5° – 20°	Wooden substrate OSB min. 18 mm	EPS min. 100 kpa, thickness max. 250 mm MW min. 70 kpa, thickness max. 250 mm PIR min. 100 kpa, thickness max. 250 mm	Min. 8 fasteners	Fv = 7.0 KN Fh = 6.21 KN	

FDT – Legal Notice

We expressly point out that all of the above information, especially the processing and usage suggestions for the products and system accessories presented, are based on our knowledge and experience under normal conditions. Proper storage and application of the products is also assumed. Due to varying materials, substrates, and varying working conditions, no guarantee of work results or liability, regardless of any legal relationship, can be derived either from these instructions or from any oral statement. For any allegation that FDT acted intentionally or with gross negligence, the user must provide proof that they have provided FDT in writing, in a timely, complete, and accurate manner, with all information and details necessary for a proper and relevant assessment by FDT. The user is responsible for checking the products for their suitability for the intended use. FDT reserves the right to make changes to the product specifications. Third-party intellectual property rights must be observed. Furthermore, our respective terms and conditions of sale and delivery apply. Furthermore, the most recent published or available version of a product data sheet, which can be requested directly from FDT, is binding. All information, technical data, and drawings reflect the current state of technology and our experience.

Subject to technical changes. Status: 12th March 2026 | © 2026 FDT Flachdach Technologie GmbH, Mannheim

FDT Flachdach Technologie GmbH

Eisenbahnstraße 6-8
68199 Mannheim, Germany

Tel. 06 21-85 04-0
Fax 06 21-85 04-2 00
www.fdt.de